

AH-9717

Manual Call Point



AH-9717 with base

AH-9717

Features

- Emergency press alarm, immediately activates fire alarm signal.
- Indicator light above fire alarm push-button confirms the alarm signal transfer.
- There are a phone jack and reset button behind the cover cap.
- Type I is simultaneous dual loop, Type II is simultaneous dual signal transfer (refer to diagram below)
- Optional base is available.

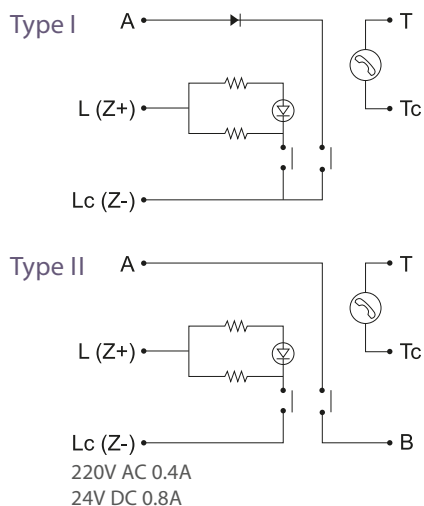

Specifications

Model	AH-9717
Operating Power	24V DC 30mA
Operating Contact	Max. 30V DC 500mA
Sub-function	Phone jack, confirmation LED, reset button.
Material	Fire-proof plastic
Dimensions	140mm(Dia.) x 45mm(H)
Weight	About 160g



Distributor in Vietnam:

VIET BAO FIREFIGHTING AND PREVENTING EQUIPMENT COMPANY LIMITED.



140 Nguyen Van Thu St (Ground floor), DaKao ward, Dist.1, HCMC.

Tel: 84.28.39101156 – 39101157. Fax: 84.28.39101158

Email: vietbao@vietbaopccc.com.vn Website: <http://vietbaopccc.com.vn>